

# USER MANUAL

NAME: **GPS VEHICLE TRACKER  
GPS + GSM + SMS / GPRS**

MODEL: **GT06N**



**PLEASE READ THE INSTRUCTIONS  
BEFORE USING THE UNIT.  
SAVE IT FOR USE IN THE FUTURE.**

Safety Warning & Attentions .....	3
1. Attention .....	3
2. Attention for operation of this product.....	3
3. Operation and maintenance .....	3
Product Overview - Model: GT06N.....	3
1. Accessories:.....	3
2. Appearance:.....	4
3. Usage: .....	4
4. Performance parameters:.....	4
5. LED Indicators Status: .....	5
Getting Start.....	5
1. Install the SIM card .....	5
2. Install the device .....	5
3. Wiring configuration .....	6
4. Device wiring diagram .....	6
5. Power/ACC/Tele-cutoff(petrol/electricity) control line (4 pin).....	7
Quick Operation Instructions .....	7
1. APN setting .....	7
2. DNS setting.....	7
3. ON /OFF GPRS.....	7
4. Add specific number.....	7
5. Delete specific number.....	8
6. Set the center number.....	8
7. Delete the center number .....	8
8. Check parameter setting.....	8
9. Check GPRS parameters.....	8
10. GPRS time interval .....	9
11. Sensor alarm time setting.....	9
12. Restore to factory setting .....	9
13. Reboot device .....	9
1. Power on/ Power off.....	9
2. Check location.....	9
3. SOS alarm.....	9
4. Wire cut-off alarm.....	10
5. Low battery alarm.....	10
6. Vibration alarm .....	10
7. Voice monitoring.....	10
8. Oil cut-off .....	10
9. Restoring Oil.....	10
10. Over speed Alarm .....	11
Web based tracking online activation.....	11
Trouble shooting .....	11
Warranty instructions and service .....	11
Statement.....	11

## Introduction

Thank you for choosing this GPS Vehicle Tracker. Please read this Manual carefully to fully understand its usage, perfect functions and simple operation. This product not only provides tracking function but also provides cutting petrol or electricity of your car to meet your requirements of monitoring comprehensively car security. The Company reserves the right to modify this Manual from time to time without prior notice. Before using this product, please read these Attentions carefully to ensure safe and proper operation of this product.

## Safety Warning & Attentions

### 1. Attention

- Do not place this product on an uneven or unstable table-board to prevent failure or damage caused by falling.
- Only the battery designated by the Company can be used on this product. Application of other products may lead to leakage, overheating, blowout and fire of the battery.
- Do not crash, vibrate, or throw device in order to avoid failure and fire.
- Do not use this product in a place with flammable and explosive gas; otherwise, product failure and fire may be caused.
- Do not place this product in a place with high temperature, high humidity or large amount of dust; otherwise, product failure may be caused.

### 2. Attention for operation of this product

- Do not dismantle or remodel this product, otherwise, damage, creepage and electrical fault may be caused to this product.
- Place tiny metal objects such as drawing pin at a place far away from the speaker. As the speaker has magnetic property while working, it will attract these tiny metal objects, which may lead to personal injuries or damage of the speaker.

### 3. Operation and maintenance

- Please keep this product dry, as rainwater, moisture, humidity and liquids or moisture content may contain mineral matters that erode the circuit.
- Do not keep this product in any place with high temperature. As high temperature may shorten the lifespan of electronic device, damage the battery and cause deformation or melting of certain plastic parts and components.
- Do not keep this product in any place with low temperature. As when being moved from a place with low temperature to a place with normal temperature, it may generate humidity inside, which may cause damage of circuit board.
- Do not attempt to dismantle this product. As improper handling by nonprofessional personnel may cause damage of the device.
- Do not toss, knock or shake this product, as tough operation mode may damage the motherboard inside the device.
- If this product is made wet by mistake, shut it down, remove the battery, and restart the product after confirming it complete dry after 24 hours.
- Use clean and dry soft cloth to clean the lens, infrared lamp and light sensor.

**Warning: improper operation will void warranty!**

**GPS Vehicle tracker**

## Product Overview - Model: **GT06N**

### 1. Accessories:

Device  
Power cord  
Relay  
Microphone  
SOS alarm cable & button  
User Manual

Please make sure that all accessories are complete. Pictures are for indication and illustration purposes only.

## 2. Appearance:



## 3. Usage:

- for cars
- for vans
- for trucks
- for camper
- for buses
- for other vehicles

## 4. Performance parameters:

Serial	Specifications	Technical parameters
1	Dimension	106(L) x 54(W) x 16(H) mm
2	Weight	96g
3	Backup Battery	450mAh / 3.7V
4	Operation Temperature	-25 °C-60 °C
5	Humidity	5% - 95%
6	Standby Time	160 hours
7	GSM Frequencies	850/900/1800/1900 MHz
8	GPRS	Class 12
9	GPS Channel	20
10	GPS Sensitivity	-159dBm
11	Acquisition Sensitivity	-144dBm
12	Position Accuracy	10m
13	TTFF (Open Sky)	Cold Start <38s / Warm Start <15s / Hot Start <2s
14	GSM/GPS Antenna	Built-in design
15	LED Indicator	GSM-green, GPS-blue, Power-red
16	Data Transmit	TCP, SMS
17	Geo-fence	View any existing Geo-fence in the map
18	Speeding Alarm	Report when speeds higher than the pre-set value.
19	Low Power Alarm	Alarm when backup battery is running out
20	Non-movement Detection	Movement alarm based on built-in 3D motion sensor
21	Mileage Report	Track by time/distance interval
22	Remote Control	Cut off petrol/electricity

## 5. LED Indicators Status:

### GPS LED Indicator – Blue

Status	Implication
Flashing (interval 0.1s)	Searching GPS signal
Solid blue	GPS fix
OFF	No GPS fix or initializing

### GSM LED Indicator – Green

Status	Implication
Quick flashing (interval 0.1s)	GSM initializing
Slow flashing (flash 0.1s every 2s)	Receive GSM signal normalny
Solid green	Connected to GSM Network
OFF	No GSM Signac

### Power Status – Red

Status	Implication
Flashing (interval 0.1s)	Low battery
Slow flashing (interval 0.2s)	Full charge
Slow flashing (flash 0.1s every 2s)	Normal operating
Solid Red	Charging
OFF	Low battery/Power off

Notice: Ignition detection indication: three LED indicators take turns flashing.

## Getting Start

Please follow below instructions for ensuring safe and correct use.

### 1. Install the SIM card

Place the SIM card into the device with the gold-colored side facing down.

**Note: Make sure there is enough credit on the SIM card. If you will be using the GPRS function, you should pay attention to the current SIM card GPRS charge.**

### 2. Install the device

You need to choose somewhere that it won't be found, because the whole point of fitting covert GPS vehicle tracker is the secrecy element. Installation please refers to below picture.

- Under the dash board below the front windshield;
- In the parcel shelf in the rear;
- In the front bumper( non-material face), please ensure the device cannot get wet;
- Under the wiper version (non-metal), please ensure the device cannot get wet;
- Non Covert Installation, firstly fix the device on the dash board below windshield.

**NOTE: 1. If the windshield is pasted with metal thermal-protective coating, it may affect the performance of the device. In this case, please change the installation place after consulting the professional.**

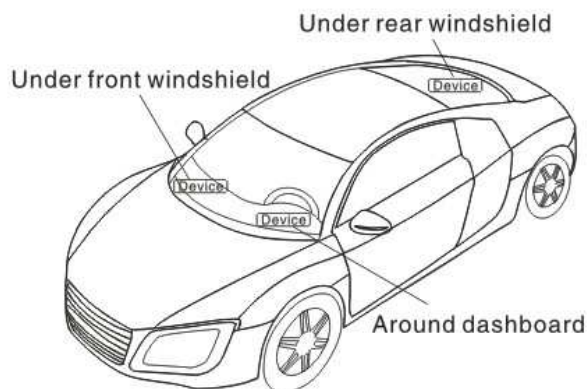

**2. Any high power devices such as reversing radar, anti-theft device or communication equipment would affect the signal of the device.**

**3. All metallic cases of the windshield will attenuate the signal on the tracking device. It's simply due to the shielding effects of the metal compound of the case.**

### 3. Wiring configuration

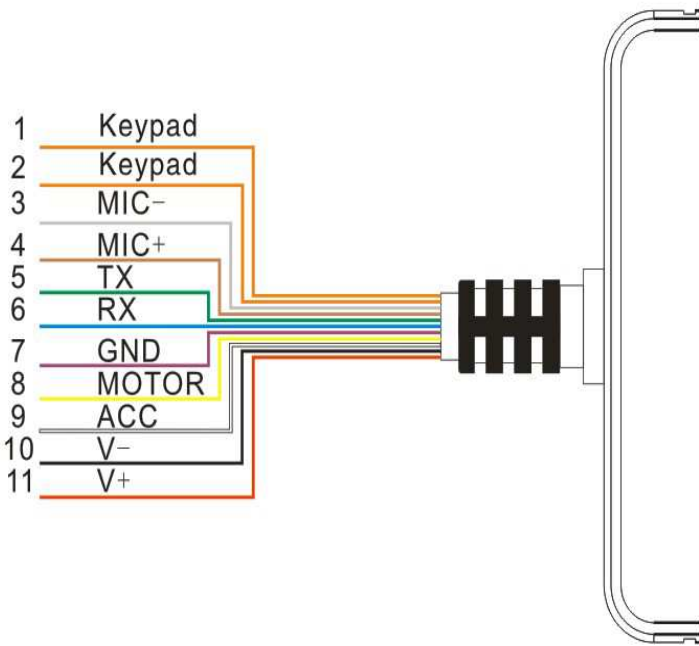

#### Notes of the relay wiring

The relay wiring of pump: oil connectors of both ends are a fine white line (85) and a fine yellow line (86). The fine white line (85) is connected to vehicle positive power (+12V). The fine yellow line is connected to the device relay control line.

Cut off the positive connection line of the pump; then connect in series to the relay N.C. contact (thick green line 87a) and the other end to relay COM contact (thick green line 30).

Line No.	Specification	Color	Instruction
1. 2	Keypod	Orange / Orange	Connect to SOS button
3. 4	MIC-,MIC+	Black / Red	Connect to Microphone
5	TX	Green	Sending data (TX) / backup
6	RX	White	Receiving data (RX) / backup
7	GND	Black	Ground wire
8	MOTOR	Yellow	Connect to relay control line
9	ACC	White	Connect to ACC ignition
10	V-	Black(thick)	Negative side of 12V/24V car storage battery.
11	V+	Red(thick)	

### 4. Device wiring diagram

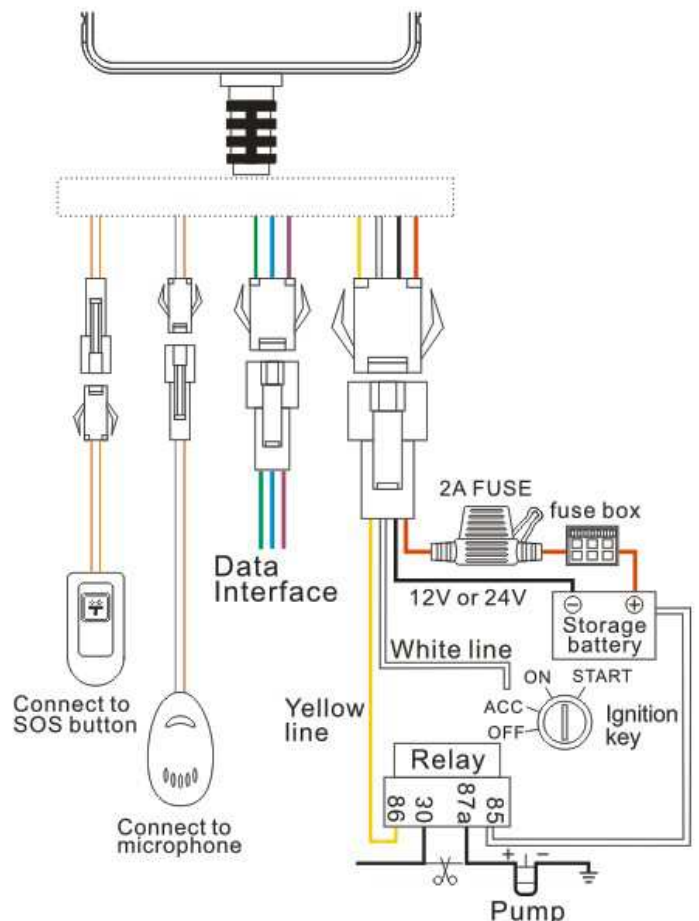

Please choose the right relay (12V-standard / 24V-optional) for the proper installation.

## 5. Power/ACC/Tele-cutoff(petrol/electricity) control line (4 pin)

1. Your device comes with a power cord and is designed to use only manufacturer-specified original device. The red line is positive while the black one is negative (the side should not be connect with ground wire).
2. The ACC line (white) connects to ACC switch of the vehicle. Please be sure to connect the ACC line; otherwise the device will enter ignition detection status when disconnect the ACC line. If you don't need to anti-theft temporarily, just connect the ACC line to the positive side in parallel.
3. Tele-cutoff (petrol/ electricity) control line (yellow) is connected to pin 86 of the Tele-cutoff (petrol/ electricity) relay (equal to the yellow line of the relay socket).
4. USB cable (3 pin)  
Firmware updating interface/expanded function to reserve space.
5. MIC line (2 pin)  
Externally connect to microphone for voice monitoring function.
6. SOS line (2 pin)  
Externally connect to SOS switch for SOS function.

## Quick Operation Instructions

Operation Tips: To properly use the device, common parameters should be set before initial use. This can be done by using the parameter editor or by sending SMS commands to the device. (","should be English comma and no space before and after the comma)

### 1. APN setting

To connect default platform [www.gpsyeah.com](http://www.gpsyeah.com), please send the SMS command below:APN command format: **APN,APN's Name#**

E.g: **APN,internet#** ("internet" is the APN of carrier)

The device will reply "OK" if setting successfully.

**Note: The APN of some countries have user name and password, you may need to send SMS command as following:**

**APN,APN name,user name,password#**

E.g: **APN,internet,CLIENTE,AMENA#**

### 2. DNS setting

To connect other platform, please send the two SMS commands below:

Command format:

**APN,APN's Name#**

**SERVER,1,DNS,Port,0#**

E.g: **APN,internet#**

**SERVER,1,www.gpsluckly.com,0088,0#** (for internet platform [www.gpsyeah.com](http://www.gpsyeah.com))

It will reply "OK" after set successfully.

### 3. ON/OFF GPRS

When you want to disable GPRS, you can SMS command to the SIM card number which used in the device.

Command format:

GPRS ON: **GPRSON,1#**

GPRS OFF: **GPRSON,0#**

It will reply "OK" after set successfully.

### 4. Add specific number

SMS command to the device to set the SOS number.

**SOS,A,No.1,No.2,No.3#**

"A" means to add new numbers, for example:

SOS,A, 13510905991,13510905992,13510905993#

If there is only one SOS number, you can appoint a specific number as SOS number. And the null means no adding.

For example:

SOS,A,13510905991# means to set the first number as SOS number

SOS,A,,13510905992# means to set the second number as SOS number

SOS,A,,,13510905993# means to set the third number as SOS number

If set successfully, there is a "success" reply SMS.



## 5. Delete specific number

Before deleting specific number, please check its corresponding code. For the code, please SMS "PARAM#" to the device. SMS command to the device to delete the number.

**SOS,D,serial NO.1,serial NO.2,serial NO.3#**

"D" means to delete the number, for example:

SOS,D,1# means to delete the first number

SOS,D,3# means to delete the third number

If you want to delete more than one numbers, you can send this command:

SOS,D,1,3# means to delete the first and third numbers.

If you forget serial number of the mobile number you want delete, you can send this command:

SOS,D,mobile number# means to delete the mobile number directly.

For example:

SOS,D,13527852360# means to delete the 13527852360 directly.

After deleting the SOS number, it will receive "Delete number 135XXXXXXX success! specific number total 2" for successful deleting of the specific number.

## 6. Set the center number

If you want to cut off/restore oil by SMS command, you have to set a center number firstly. Only the center number can send the cut off/restore oil command to the device. You can set your own mobile number as center number.

The command for setting center number is:

**CENTER,A,mobile number#**

For example: CENTER,A,15942703401#

If set successfully, there is an "OK" reply message.

**NOTE: Only the SOS number can be used to set center number successfully.**

## 7. Delete the center number

SMS command to the device to delete the center number.

The command is: **CENTER,D#**

For example: CENTER,D#

If set successfully, there is an "OK" reply SMS.

**NOTE: Only the SOS number can be used to delete center number successfully.**

**Only SOS phone number can send this command successfully to set the center number. There is only one center number can be set.**

## 8. Check parameter setting

Send command to the terminal, you can check the parameter setting.

Command format: **PARAM#**

e.g.: PARAM#

Information replied:

IMEI: 353419032348877 ---IMEI number of the device;

GPRS Interval: 10,10; ---GPS data uploading Interval;

SENDS:5; --- the GPS working time when ACC is OFF;

SOS: 15942703401; --- SOS numbers, maximum 3 SOS numbers can be set and used for alarm and monitoring;

Center Number: 15942703401; ---only 1 center number can be set and used for cutting off /restoring oil command;

Sensoralm: 10,3,1,180 --- detect 3 vibrations in 10s; the alarm delay is 180s;

Defense time: 10; --- the defense delay is 10 minute;

TimeZone:E,8,0; --- set time zone; default as E8.

The replied information contains IMEI number, GPRS Interval, SENDS, SOS, center number, sensor time interval, defense time and time zone.

## 9. Check GPRS parameters

SMS command format: **GPRSSET#**

Eg: GPRSSET#

Reply message:

GPRS:ON //GPRS on/off status//

APN:CMNET,0,0.0.0.0,;; //APN setting information//

Server: **1,www.gpsluckly.com,0088,0;** //platform information//

URL:http://maps.google.com/maps?q=; //preset web link setting information //



## 10. GPRS time interval

The default GPRS time sending interval is 10s which means the device will upload positioning data to the platform server every 10s. Users can modify GPRS time sending interval by SMS "**TIMER,time(second)#**".

The time ranges from 10-18000s

For example: **TIMER,10#**

It means the device will upload data to the server every 10s.

## 11. Sensor alarm time setting

When the vehicle power is off and ACC is in low-level, if ACC is off over 10 minutes, the device will enter sensor alarm state. In this case, if the vehicle vibrates for a few times, it will activate the vibration alarm system. If the vehicle battery is still not on (ACC is in low level) after 3 minutes, the device will start vibration alarm.

SMS format: "**DEFENSE,TIME(minutes)#**" The time ranges from 1 to 60 mins.

For example: **DEFENSE,15#**. It means when ACC is in low level for 15mins, it will enter sensor alarm status (vehicle power is off)

### NOTE:

1. Preset SOS numbers when send SMS alarm messages and calls
2. If there is no need for vibration alarm, please SMS **SENSOR,0#** to close it.

## 12. Restore to factory setting

SMS command format: "**FACTORY#**" to set all parameter to default factory value. Once received "OK", it succeeds.

## 13. Reboot device

When there is something wrong with the link of GPRS, e.g., The parameter setting of the device is correct, but you can't track the car on the platform. At this moment you can send a command to the device to reboot the device.

The format is: **RESET#**

After receiving this command, the device will reboot after 1mins.

## Operation of device

### 1. Power on/ Power off

Power on: Once insert a valid SIM card and connect all the wires, turn on the device, then Power LED will flash first, During signal searching process, GSM and GPS LED will flash. Once GPS LED keeps solid light, it means the device has been located and it starts to work.

Power off: Just turn off the power switch.

The device will begin to upload positioning data to server once inserting a valid SIM card and power on. During the working time, it can upload data to server every 10 seconds.

### 2. Check location

#### 1. Via SMS

1.1 SMS "**WHERE#**", to the SIM number of device. The device will send a location message automatically. You can get the coordinates. If the device does not search any information of location, it will send "No data" to the cell phone.

**Example:**

**Lat:N22.571285,Lon:E113.877115,Course:42.20,Speed:0.0740,DateTime:10-11-23 22:28:51**

1.2 SMS "**URL#**", to the SIM number of device. The device will send a location Google Map link. If the device does not search any information of location, it will send "No data" to the cell phone.

**Example:**

**<Date Time : 10-11-23 23:42:51> http://maps.google.com  
/maps?q=N22.571490,E113.877103**

#### 2. Via platform

Go to the platform website offered by dealers to check your vehicle location.

### 3. SOS alarm

In emergent case, press SOS for 3s to activate SOS alarm. Then the device will send SOS SMS to preset specific numbers and then dial the numbers in circles until the call is picked up. At the meantime, the device will upload SOS alarm data to the server. And it will send:

SOS Alarm! <DateTime:11-06-17 14: 53: 06>, <http://maps.google.com/maps?q=N22576713,E113.916585>

**Note: The specific numbers should be preset, just refer to 4**

#### 4. Wire cut-off alarm

When the electricity supply of device is cut off, it will activate cut-off alarm. In this case, the device will send related SMS to the specific numbers and dial the numbers in circles. If nobody answers, the call just keeps 3 loops at most. At the meantime, the device will upload SOS alarm data to the server. And it will send:

Cut Power !<Date Time:11-06-17 14: 53: 06>, <http://maps.google.com/maps?q=N22576713,E113.916585>

**Note: The specific numbers should be preset, just refer to 6.4**

#### 5. Low battery alarm

When the device is only working with battery, once the internal voltage of battery is less than 3.7V, device will send low battery alarm sms to specific number and alarm on platform.

Low battery alarm sms content example: "Attention!!!battery too low, please charge." Which means the battery is to low, to inform user charging it in time.

**Note: The specific numbers should be preset, just refer to 6.4**

#### 6. Vibration alarm

The vibration alarm function is off by default. To activate this function, please send the following command: SENALM, ON#. The alarm will be sent to both the service platform and SOS numbers.

When vehicle power is off, ACC status is low, and if the lead time of low ACC is more than 10 minutes (settable), device will activate security alarm. When the security alarm is on, once the vehicle vibrates for several times, the alarm will be activated; in the next 3 minutes, if vehicle power is still off (ACC status is low), device will start alarm. At this time, it will send alarm message to the service platform with the latitude and longitude, while the platform will reply the Chinese address. Then the terminal will send vibration alarm message to SOS numbers with the Chinese address, and call the SOS numbers in cycle. If nobody answers, it will stop calling after 3 loops.

If the Chinese address can not be acquired for certain reason, the terminal will send a message with the website link to the SOS numbers.

e.g.:Sensor Alarm !<11-23 14:53>, <http://maps.google.com/maps?q=N22576713,E113.916585>

**Note:**

**1.The SOS numbers should be preset.**

**2.Send "SENSOR, OFF#" to turn off the vibration alarm.**

#### 7. Voice monitoring

When the special number cell phone dial device, ringing for 10 seconds, it will enter voice monitoring status. At this time, caller can monitoring the sound in vehicle. Incoming call from non special number will not activate voice monitoring function.

**Note:To realize this function, please set special number beforehand.**

**The SIM card put into the device should be equipped with caller identification.**

#### 8. Oil cut-off

##### 1. Via platform

Send oil cut-off command on platform. To make sure the security of vehicle, tracker can only indicate to cut off oil when GPS is in valid position status, and the speed is less than 20KM/H or in static. Platform account password is needed when sending oil cut off command.

##### 2. Via SMS

Firstly, you should set a center number. Please refer to 6.6.Only center number can send the command to the device to cut off and restore oil.

The format is: **RELAY,1#**

After the command is carried out, it will reply "Cut off the fuel supply: Success! Speed:0 Km/h". If the command didn't carry out, it will reply the reason about fail to carry out.

**Note: To ensure the safety of the driver and the car, this command is valid only under two conditions: the GPS is located; the speed is less than 20km/h**

#### 9. Restoring Oil

##### 1. Via platform

When the alarm is off, sending recover oil commands manually. Device will restore oil supplying, and vehicle will work normally again.

Platform account password is needed when sending oil cut off command.

##### 2. Via SMS

Only center number can send the command to the device to restore oil.

The format is: **RELAY,0#**

After the command is carried out, it will receive "Restore fuel supply:Success!"

## 10. Over speed Alarm

When the car is moving over a limited speed in average in a limited time period, then the device will send over speed alarm SMS to user.

To turn on the over speed function, please send below SMS command: **SPEED,Time,Limited speed#**

Time range ( Second ) : 5-600s (default as 20s)

Limited speed range ( km/h ) : 0-255 (0 refers to turn off over speed alarm function)

Example: SPEED,3,120#

Means when the car is moving over 120km/h in average in 3 minutes, the device will send over speed alarm to user.

## Web based tracking online activation

The GPRS web based tracking platform allows real time tracking with the latest Google maps. There is also a playback feature that allows you to view where the vehicle has been for up to 30 days in the past making it ideal for fleet management.

## Trouble shooting

If you are having trouble with your device, try these troubleshooting procedures before contacting a service professional.

<b>Problems</b>	<b>Causes</b>	<b>Solutions</b>
<i>Fail to connect platform</i>	<i>The fuse blows</i>	<i>Replace the fuse</i>
	<i>ACC ignition disconnected</i>	<i>Turn on ACC with key</i>
<i>Fail to connect network</i>	<i>Wrong installation of SIM card</i>	<i>Check SIM card installation (Refer to 4.1 Install SIM card)</i>
	<i>Filth on the SIM card iron surface.</i>	<i>Clean it</i>
	<i>Useless SIM</i>	<i>Contact internet service provider</i>
	<i>Improper installation</i>	<i>Check installation of device (Refer to 4.2 Install the device)</i>
	<i>Beyond GSM service area</i>	<i>Use it in effective GSM service offer area</i>
<i>Fail to charge</i>	<i>Bad signal</i>	<i>Try again in a better signal area</i>
	<i>The voltage is unsuitable</i>	<i>Connect with power with suitable voltage</i>
	<i>Improper connection</i>	<i>Check connection with charger</i>

## Warranty instructions and service

1. The warranty is valid only when the warranty card is properly completed, and upon presentation of the proof of purchase consisting of original invoice indicating the date of purchase, model and serial No. of the product. We reserve the right to refuse warranty if this information has been removed or changed after the original purchase of the product from the dealer.
2. Our obligations are limited to repair of the defect or replacement the defective part or at its discretion replacement of the product itself.
3. Warranty repairs must be carried out by our Authorized Service Centre. Warranty cover will be void, even if a repair has been attempted by any unauthorized service centre.
4. Repair or replacement under the terms of this warranty does not provide right to extension or renewal of the warranty period.
5. The warranty is not applicable to cases other than defects in material, design and workmanship.

## Statement

All rights reserved.  
Author instructions  
Correction

**Shenzhen Concox Information Technology Co., Ltd.**  
**ELMIC / PHU FENIKS POLAND**



Producer:

**Shenzhen Concox Information Technology Co., Ltd.**  
**China**



[www.concox.cn](http://www.concox.cn)

Importer:

**Przedsiębiorstwo Handlowo Usługowe FENIKS**

ul. Słoneczna 110,  
Nowa Kuźnica, 42-350 Koziegłowy  
Poland

[www.elmic.pl](http://www.elmic.pl), [elmic@elmic.pl](mailto:elmic@elmic.pl)

